

1

Collegamenti idraulici

- Effettuare i collegamenti alla rete idrica

Hydraulic connections

- connect the water supply network.

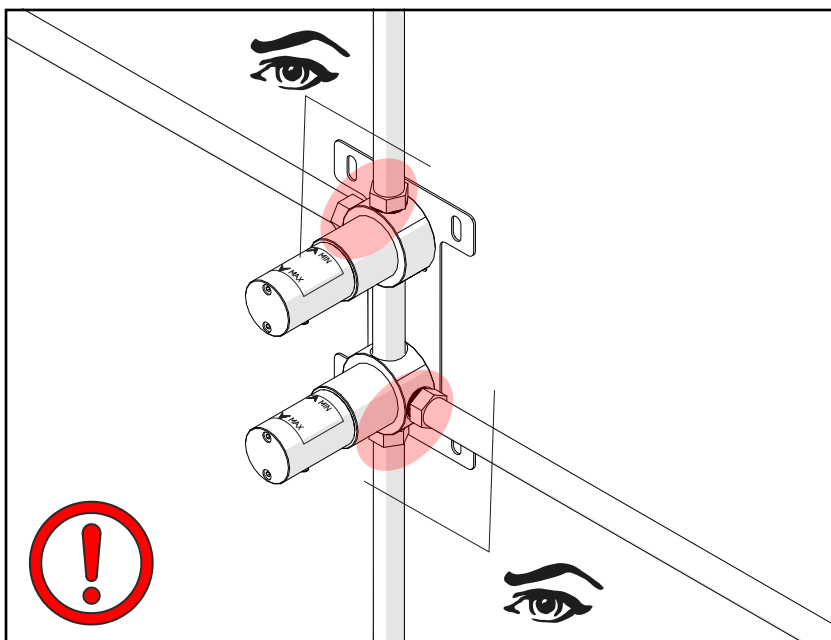

2

Controllo connessioni

- Una volta fatti i collegamenti idrici, prima di fissare la parte incasso al muro, mettere l'impianto in pressione rimuoveri i tappi, aprire le cartucce e controllare attentamente che non ci siano perdite. Chiudere le cartucce prima di procedere al passo successivo.

Connections check-up

- Once arranged hydraulic connenctions, before fixing the built-in part to the wall, put the system under pressure, remove the caps, open the cartridges and make sure that there are no leakages. Close the cartridges before proceeding with the next step.

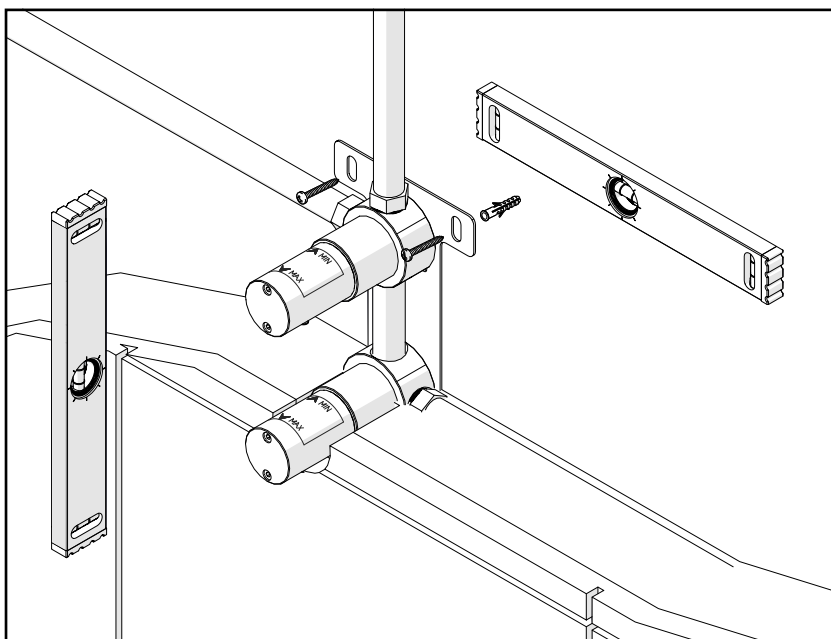

3

Installazione

- posizionare e fissare l'elemento ad incasso facendo attenzione che i tappi in plastica sporgano dalla parete finita come da indicazione dell'etichetta adesiva.

Installation

- place and fix the built-in part paying attention that the plastic caps extend from the finished wall, as indicated in the adhesive label.

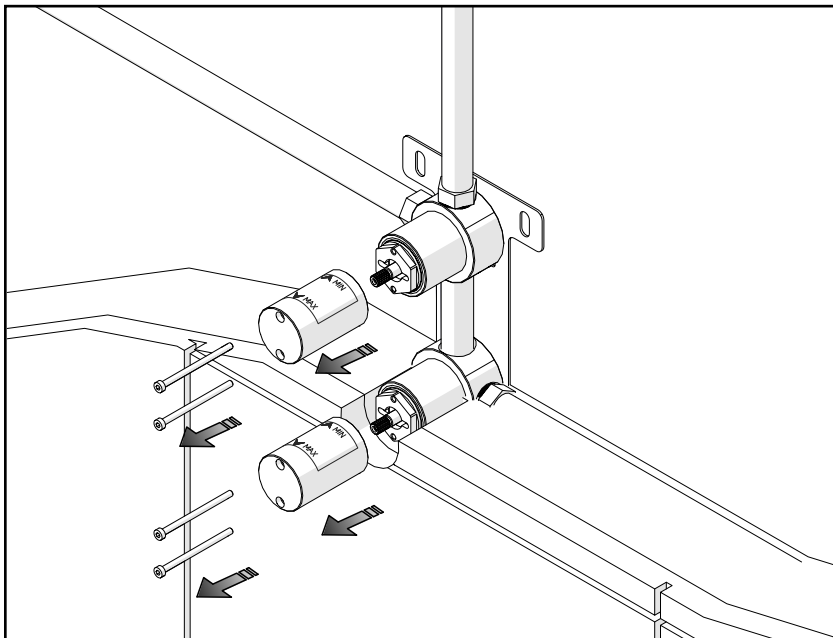

4

Rimozione tappo in plastica

- ad opere murarie ultimate, togliere i tappi in plastica.

Remove plastic caps

- when building works are done, remove plastic caps.

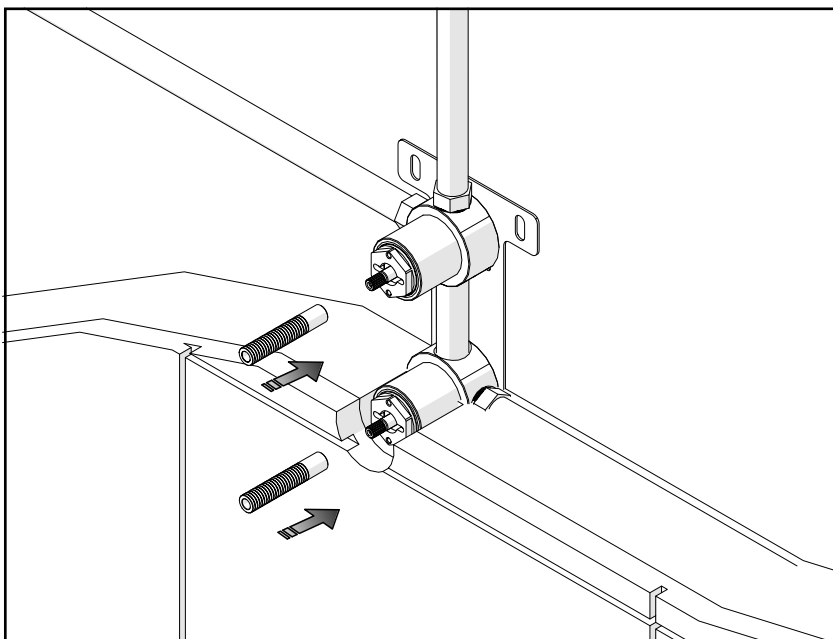

5

Montaggio perno per maniglia

- infilare il perno in dotazione con la parte esterna e verificare la misura

Mounting of pivot for the handle

- insert the supplied pivot with the external part and verify the size;

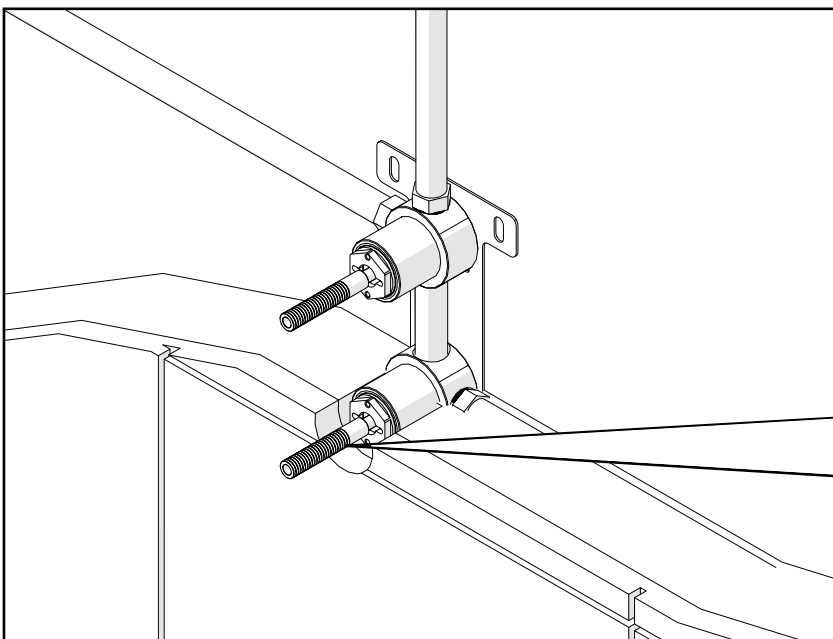

6

Rilevare misura e tagliare

- Installare perno, supporto, rosetta. Il perno deve sporgere 22 mm dalla rosetta

Measure and cut

- install the pivot, the support, the plain washer. The pivot has to stick 22 mm out of the plain washer

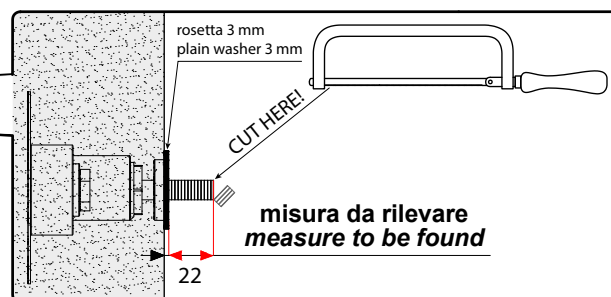

7**Fissaggio perno e supporto rosetta**

- Fissare il perno con la vite centrale e il supporto rosetta con le viti in dotazione

Fixing of pivot and support for plain washer

- fix the pivot with the central screw and the support for the plain washer with the supplied screws

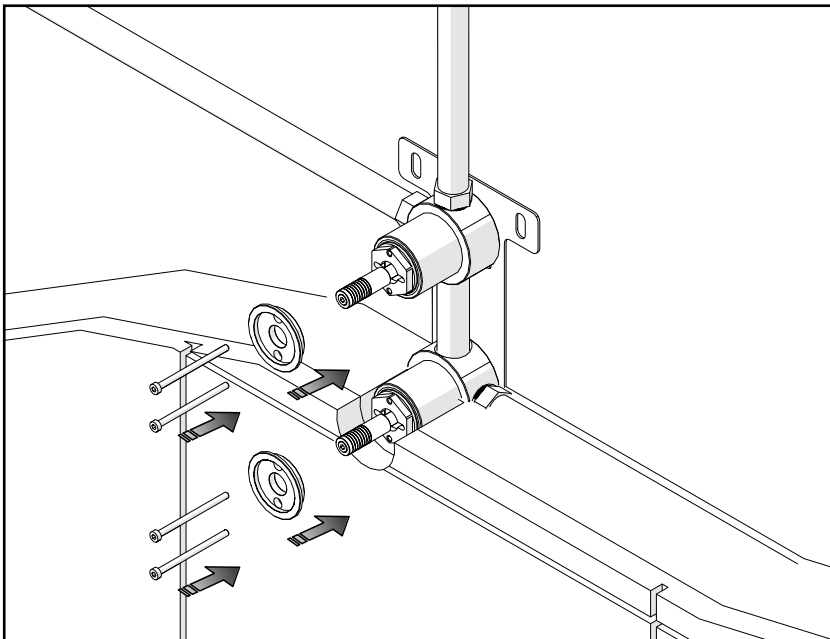
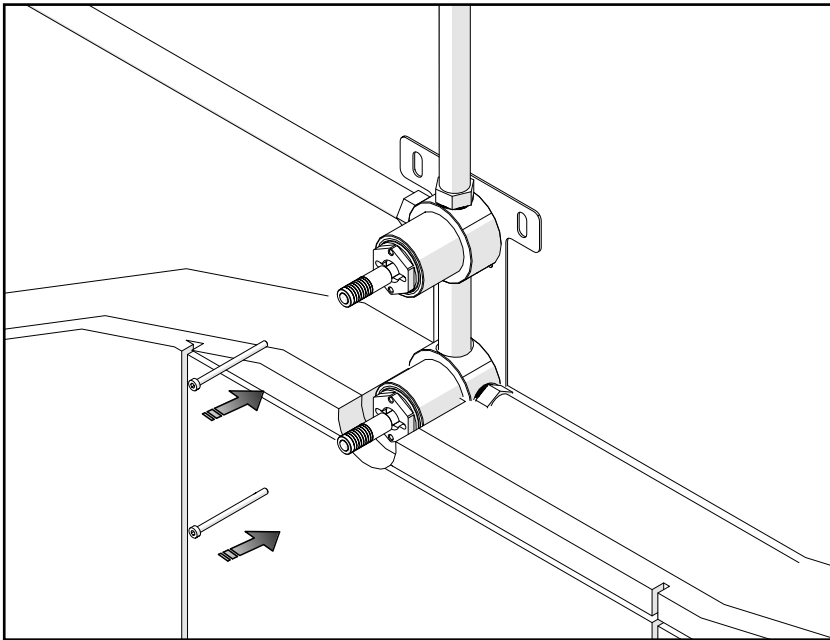
**8****Fissaggio rosetta**

- Fissare la rosetta e il distanziale spingendoli nel suo supporto

Fixing of the plain washer

- fix the plain washer and the spacer by pushing it into its support

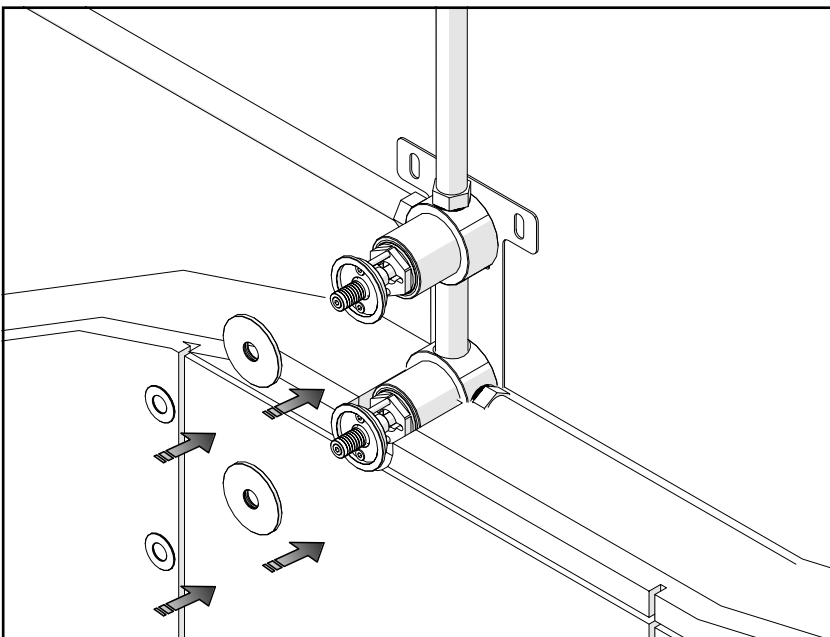

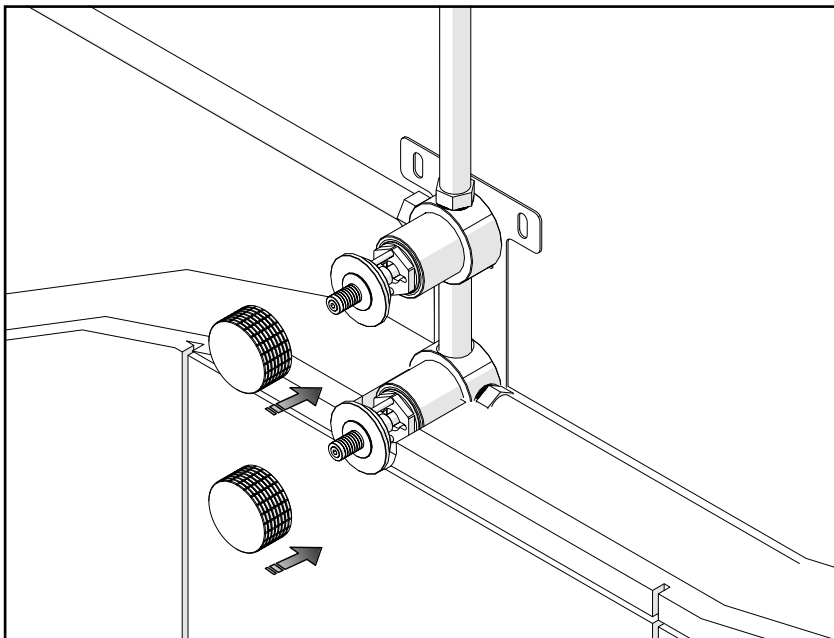

9

Fissaggio maniglia

- Fissare la maniglia con l'apposito grano come da disegno

Fixing of the handle

- fix the handle with the supplied grub screw, as shown in the picture

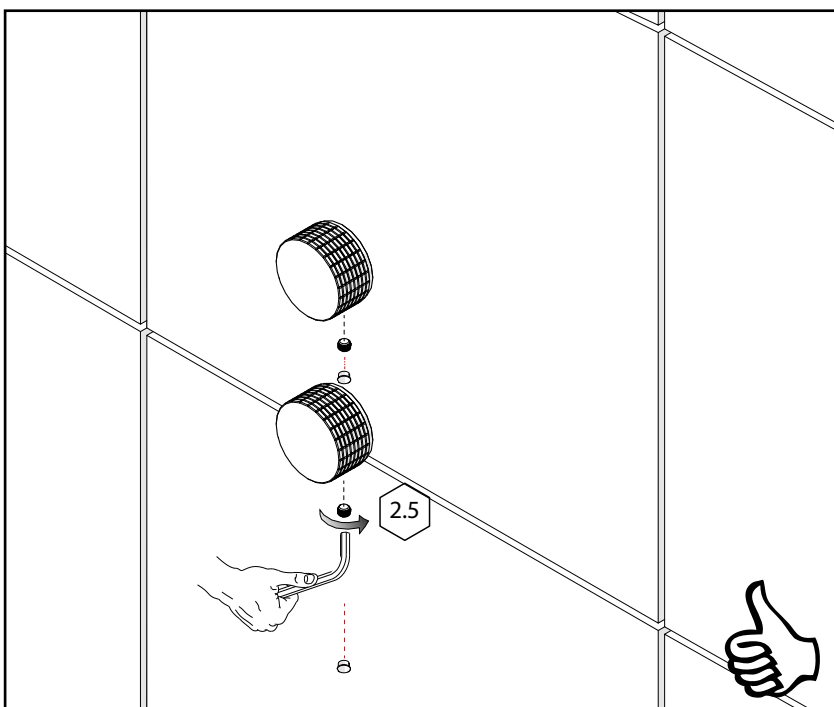

10

Fissaggio maniglia

- Coprire i fori con i tappi in dotazione

Fixing of the handle

- Cover the holes with the small caps