

ONE-STY-INS 270

Cod. INC 035

ONE 270-STY270-INS 270

1

Collegamenti idraulici

- Effettuare i collegamenti alla rete idrica

Hydraulic connections

- connect the water supply network.

2

Controllo connessioni

- Una volta fatti i collegamenti idrici, prima di fissare la parte incasso al muro, mettere l'impianto in pressione e controllare attentamente che non ci siano perdite. Chiudere la cartuccia prima di procedere al passo successivo.

Connections check-up

- Once the hook-up is complete, before fixing the built-in part to the wall, put the system under pressure. Make sure there is no leakage. Shut-off the cartridge before the next step.

3

Installazione

- posizionare e fissare l'elemento ad incasso facendo attenzione che i tappi in plastica sporgano dalla parete finita come da indicazione dell'etichetta adesiva.

Installation

- place and fix the built-in part paying attention that the plastic caps extend from the finished wall, as indicated in the adhesive label.

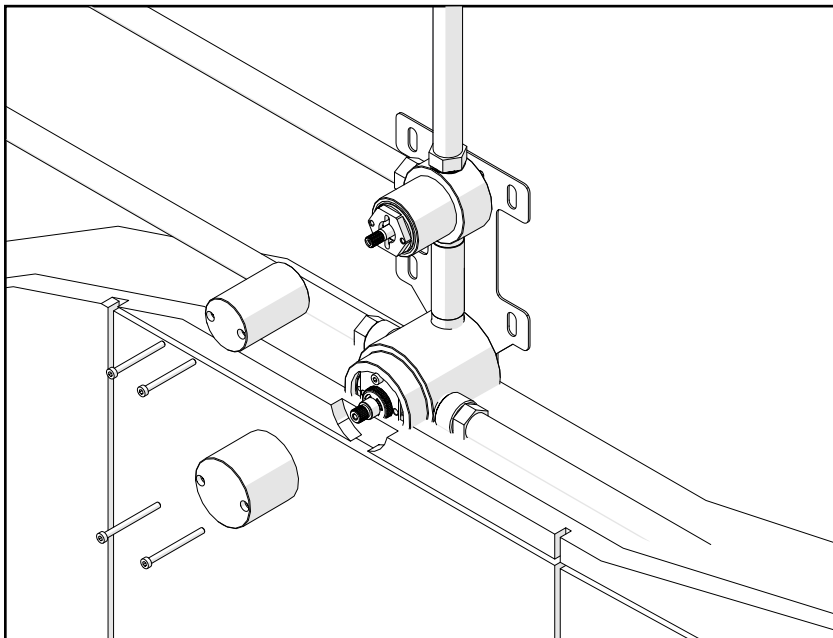

4

Rimozione tappo in plastica

- ad opere murarie ultimate, togliere i tappi in plastica.

Remove plastic caps

- when building works are done, remove plastic caps.

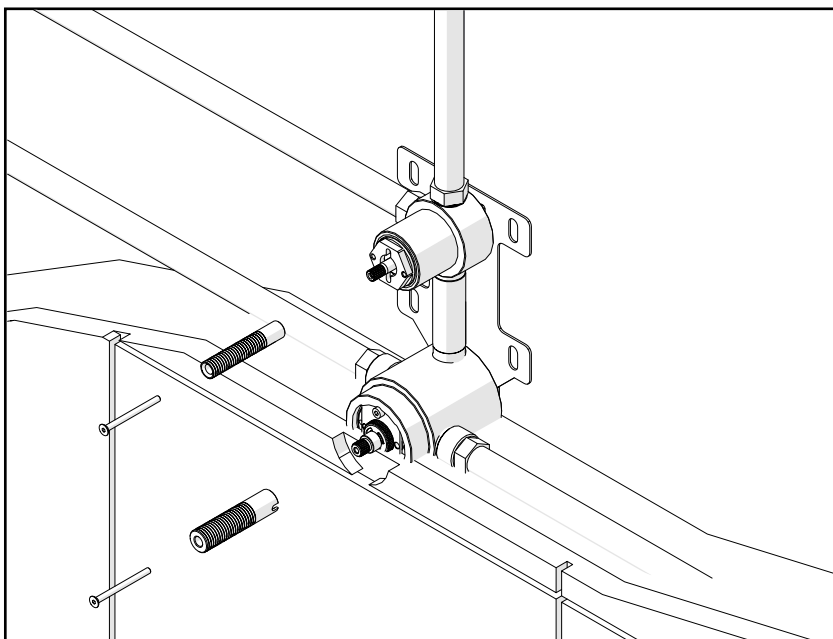

5

Montaggio perni per maniglie

- infilare i perni in dotazione con la parte esterna

Mounting of pivot for the handles

- insert the supplied pivot with the external part

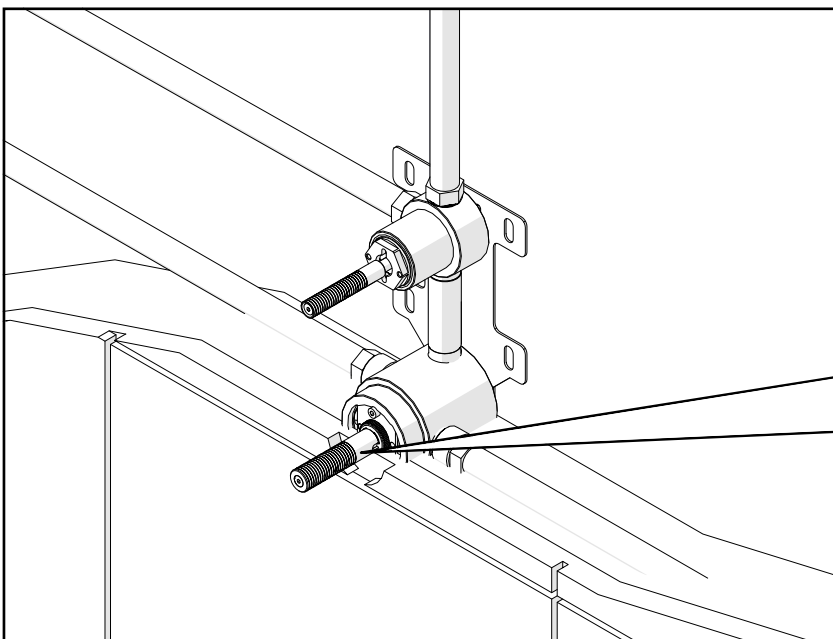

6

Rilevare misura e tagliare

- Installare perno, rosetta e maniglia e verificare la misura.

Measure and cut

- install the pivot, the plain washer and the handle and verify the size

misura da rilevare
measure to be found

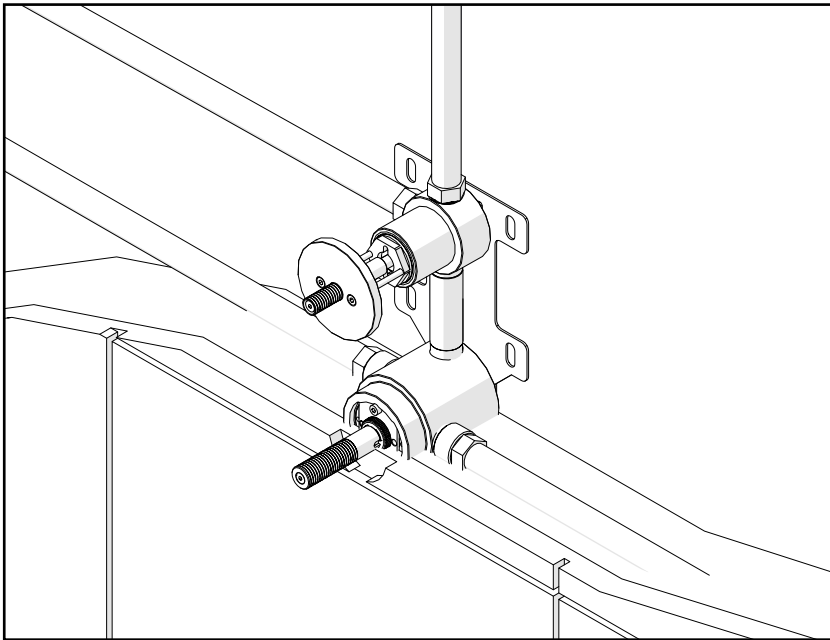

7

Fissaggio ghiera deviatore

- Fissare con le due viti in dotazione la ghiera deviatore

Deviator nut fastening

- *Secure the deviator nut using the two provided screws*

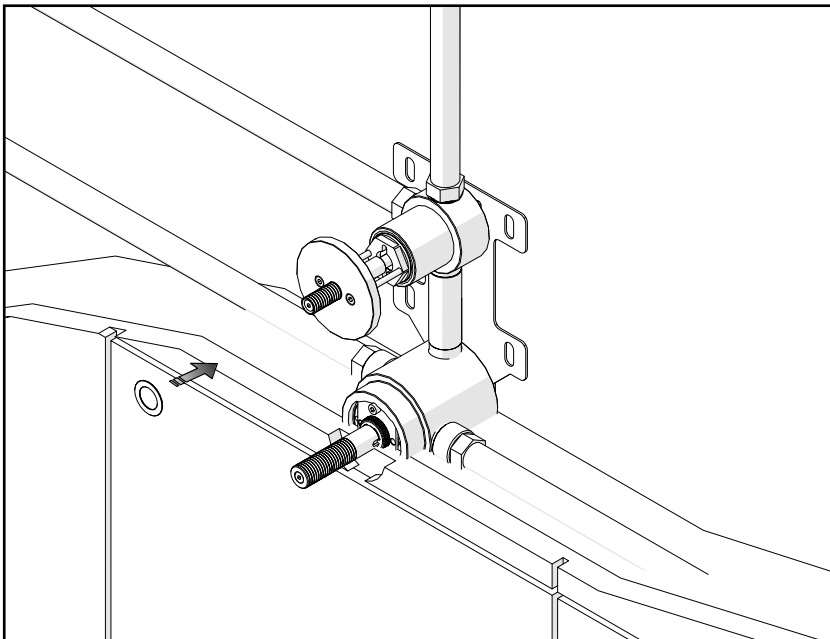

8

Distanziale

- Inserire l'anello distanziale nel perno

Spacer

- *"Insert the spacer ring onto the pin*

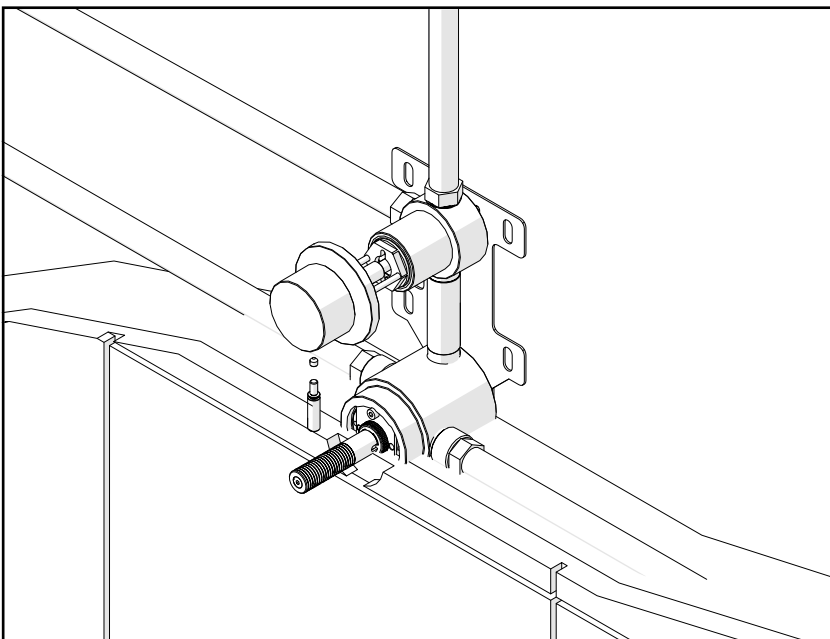

9

Fissaggio maniglia deviatore

- Fissare la rosetta spingendola nel suo supporto, fissare il grano e la leva

Diverter handle fixing

- *Secure the plain washer by pushing it into its support, then fasten the screw and the lever*

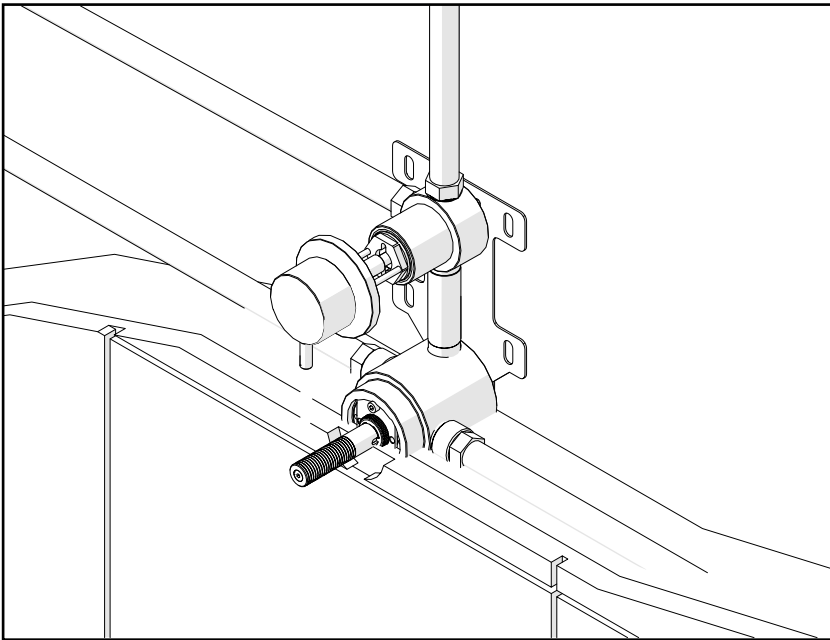

10 Fissaggio ghiera marchiata

- Fissare la ghiera marchiata tenendo i 38 gradi verso l'alto.

Secure the marked retaining ring

- *Secure the marked retaining ring while keeping the 38-degree mark facing upwards*

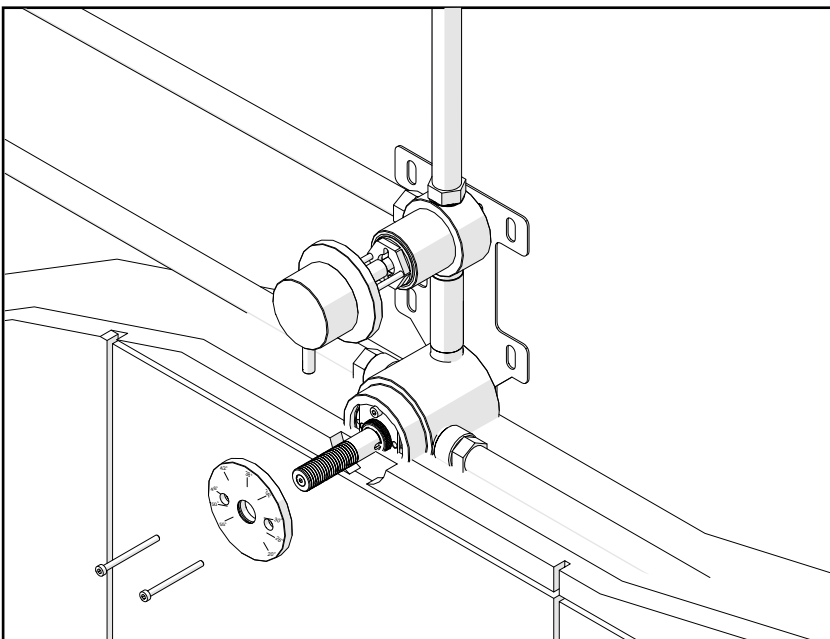

11 Distanziale

- Inserire l'anello distanziale nel perno

Spacer

- *Insert the spacer ring onto the pin*

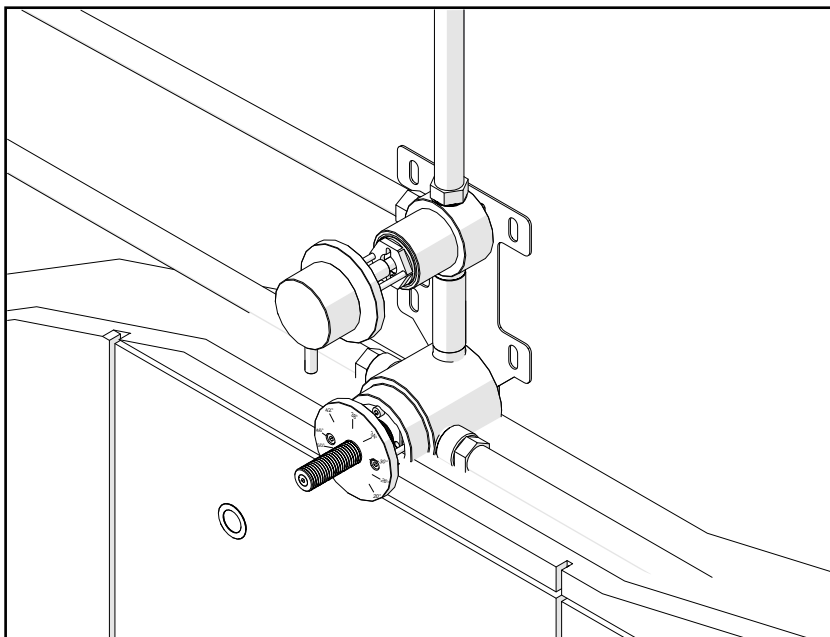

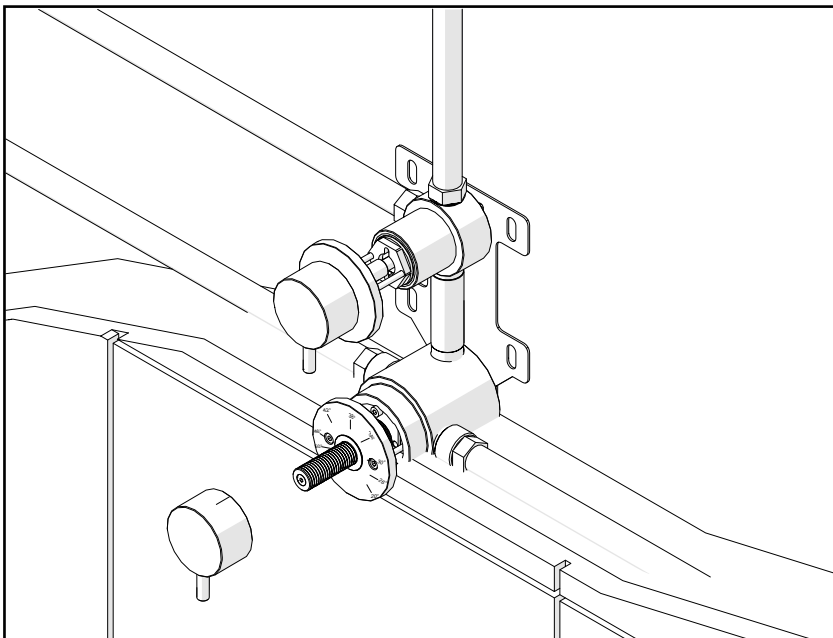

12 Installare maniglia termostatico

- Inserire la maniglia nel perno, fissarla con l'apposito grano e coprire il foro con il tappo in dotazione

Installation thermostat handle

- Insert the handle onto the pin, secure it with the provided screw, and cover the hole with the supplied cap

