

1

Scelta posizione installazione

- scegliere la posizione di installazione, quindi procedere con la tracciatura come da misure a disegno.

Select the position

- chose the position and mark a line as shown in the picture.

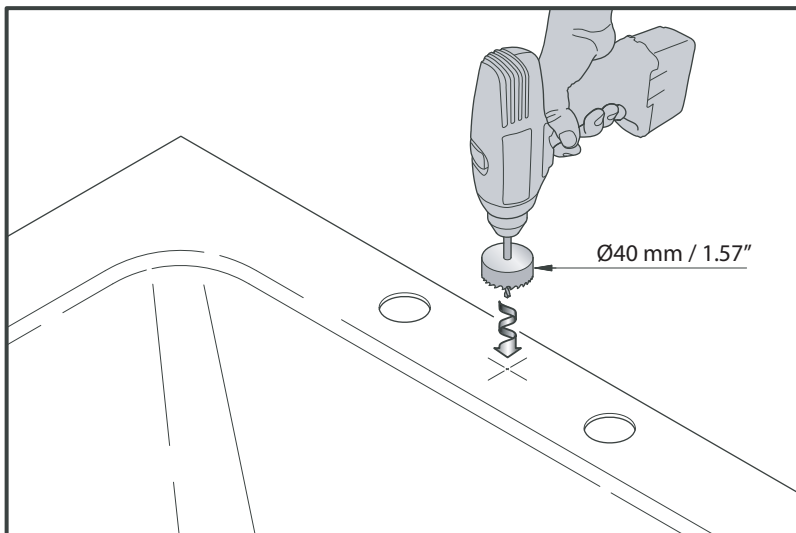

2

Foratura

- eseguire le tre forature Ø40mm per miscelatori e doccia

Drilling

- drill the three holes Ø40mm for mixers and shower hand.

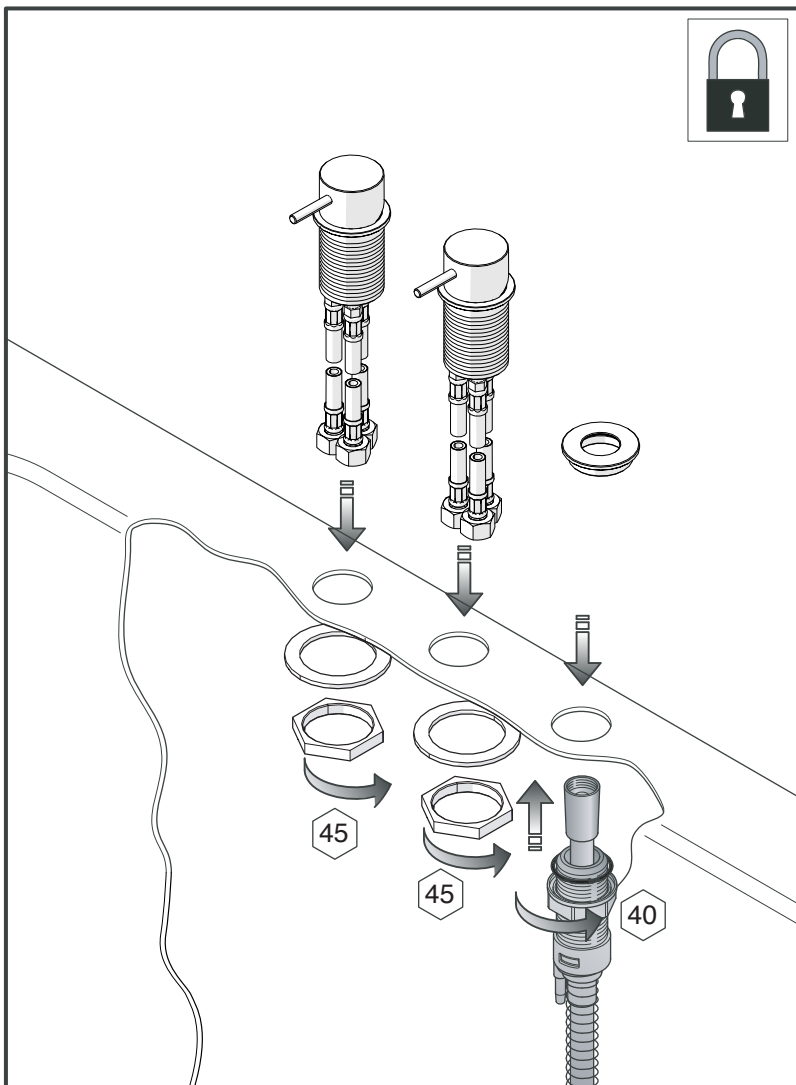

3

Montaggio sul bordo vasca

- Installare e fissare sul bordo vasca i miscelatori e il supporto doccia.

Set up

- Install and fix the mixers and hand shower holder on the edge of the bathtub.

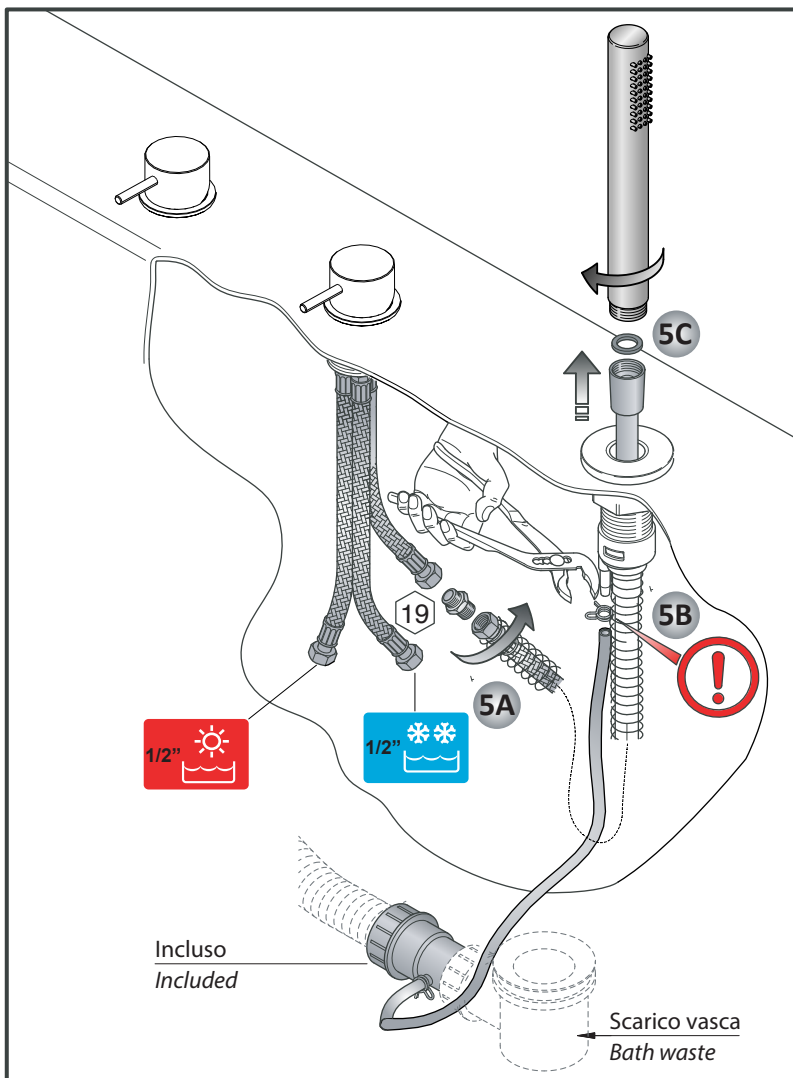

5

Collegamento miscelatore con doccia

- collegare il tubo idraulico del doccia con il tubo idraulico dell'uscita del miscelatore (5A).
- collegare il tubetto salvagocce sullo scarico della vasca utilizzando il raccordo in dotazione (5B).
- montare il doccia al suo tubo di alimentazione (5C).

Connection mixer with shower hand

- connect the tubes of the mixer to the shower-hand (5A).
- connect the recovery-tube for drops to the waste drain of bathtub, use the pug included (5B).
- set up the shower-hand to its supply tube (5C).

vers. LOP382



vers. LOP383

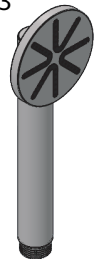

6

Collegamento miscelatore con erogazione

- collegare il tubo di uscita del miscelatore sull'erogazione vasca (troppopieno o erogazione esterna).

Connecting mixer to the water outlet

- connect the mixer outlet hose to the bathtub water outlet (overflow outlet or external spout).

7

Collegamento rete idrica

- collegare i tubi idraulici dei miscelatori alla rete idrica.

Hydraulic connecting

- connect the water tubes of the mixers to the water supply network.

